

THE BROADAXE

NEWSLETTER
of

THE SHIP MODEL SOCIETY OF NORTHERN NEW JERSEY
Founded in 1981



Volume 21, Number 7

July 2003

MINUTES OF THE REGULAR MEETING June 24, 2003

President Hegstetter called the meeting to order at 7:30 PM. There were 32 members attending. In addition, two first time visitors were with us; **Paul Steinberg** from Kendall Park and **Bill Liebold** from Browns Mill. We were also graced with the presence of two ladies; **Katelyn Herne** attending with her father and **Joan Thalmann**, **Ozzie's** wife who has chauffeur duty while **Ozzie** recovers from rotator cuff surgery.

President Ed reported that he has scheduled the September meeting at Micro Mark for September 23, 2003. Mark your calendars.

We have also been informed that the South Street Seaport Festival normally held during August has been cancelled this year because of lack of financial support.

The new membership roster was distributed to all members present. It is contemplated that this listing will be revised once a year

TECHNICAL SESSION



Dave Sasher gave an excellent presentation on using commercially available figures on models.

The largest manufacturer of model figures is Prieser whose catalog provides information on the vast range of figures they manufacture in many scales. Dave uses the basic figures but then will remove arms and legs to reposition them according to his needs.

He also suggested using figures from wedding cake scenes as well as some children's toys. Once

positioned to his needs Dave uses fillers to clean up the joints and then paint the figures with acrylic paints.



Dave Sasher with a Miniature Figure

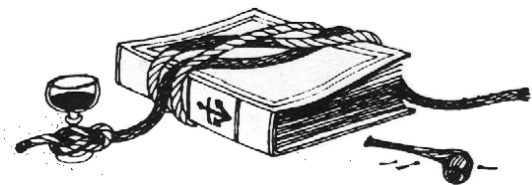

BOOKS AND PUBLICATIONS

Jeff Fuglestad had a copy of the very old book, **Ship Model Making** by A. McCann. He commented how crude some of the practices described in the book appear when compared to today's practices, but the results were nevertheless quite artful.

SHOW AND TELL

Marty Krisiloff showed his continuing progress on the Artesina Latina kit of the ocean tug **SANSON**.



Marty Krisiloff's SANSON

Don Otis had his scratch built model of the **HERZOGIN CECILE** that is now being rigged. **Don** discussed some of the techniques he employs in rigging such a large and complicated vessel.



Don Otis's Almost Complete HERZOGIN CECILE

Jeff Herne showed another **SCHNELLBOOT** from Revell of Germany. He also mentioned a new kit from Panda Models of the **ARLEIGH BURKE** in 1/350 scale. **Jeff** also told the members that a website for Ocean Liners known as the Debris Field

will be picked up within **Jeff's** own website.



Katelyn Herne Modeling a Model



Jeff's Most Recent SCHNELLBOOT

Bill Liebold, a first time visitor showed his scratch built resin model of a Spanish Frigate in 1/256 scale. **Bill's** work was excellent, and he will make a great addition to the club.



Bill Liebold's Spanish Frigate



Bill Liebold's USS INGRAHAM

More photos of **Bill's** work (taken by **Jeff Herne**) can be found at:

<http://www.modelwarships.com/gallery/ff/ffg-61/ingraham.htm> .

Martin Quinn showed his 1/600 model of the British battle cruiser **HMS REPULSE** from the Airfix kit but significantly modified with etched fittings and weathering.

Bob Fivehouse showed his ongoing work on the oceanographic research vessel **ROBERT CONRAD** that Bob is building for the Lamont-Doherty Observatory under a commission. We may not see the finished model, as Bob is under some pressure to deliver it during July



Bob Fivehouse's ROBERT CONRAD Nearing Completion



FROM THE EDITOR

I'm sure that we were all disappointed to hear that the **Thirteenth Annual South Street Seaport Model Ship and Boat Festival** scheduled for the first weekend in August this year had been canceled. **The South Street Seaport Museum** could not arrange sponsorship for funding this year's festival. SMSNNJ member **Dan Pariser** will be following the issue in the coming year and urging the museum staff to get an early start on obtaining funding for next year's show.

On a happier note, the Museum has announced plans for an extensive expansion and renovation of their museum space. We will be looking forward to hearing more about it as the plans progress. The Museum suffered a tremendous setback from the September 11, 2001 attack, and it is good to see it not only on the road to recovery but also expanding and improving its facilities. The port of New York was the primary port in the United States for most of our history. It seems appropriate that it should have a maritime museum comparable to those in other ports such as Newport News.

The **Peabody Essex Museum** in Salem, MA has recently completed a major expansion and renovation. It opened to the public on June 21. Primarily an art museum, the **Peabody Essex** has a fine collection of maritime art that would be of interest to most modelers. It was the site of the fabulous display of models from the **French Maritime Museum** in the summer and fall of 2002. Take a look at its really fine website at <http://www.pem.org/museum/>.

The **Cape Ann Ship Modeler's Guild** has issued an invitation to ship modelers to participate in an exhibition at the Danvers Art Association at the

Williams School. Danvers is just north of Boston on Route 62. The show is scheduled for October 4th and 5th and October 11th and 12th from 10AM to 5PM. It might be an interesting show to visit if you are in the Boston or Cape Ann area those weekends. I'm sure the **Guild** would welcome any SMSNNJ members and their models. For further information contact M. Consalvo, 7 Coolidge Ave., Peabody, MA 01960, telephone (978) 532-1585. He is asking that applications to display be in his hands by August 1. I have a copy of the application and information on how to reach the show. I will try

to have copies available at the SMSNNJ July, 22 meeting.

One more event that would be of interest to SMSNNJ members visiting Cape Ann is the **Gloucester Schooner Festival** presenting old schooners, a race, a sail-by and other displays. The Festival takes place on August 30 and 31. This information is provided courtesy of the **Cape Ann Ship Modeler's Guild** newsletter.

Here is another useful tip from the **Ship Modelers Association** website.

A STRIP STOCK BENDING FIXTURE

BY IRWIN FRIEDMAN

THE FIXTURE DESCRIBED HERE SHOULD OFFER HELP IN BENDING AND SHAPING TIMBER OF THE SIZE TYPICALLY USED FOR PLANKING AND DECKING. VERY OFTEN WE WOULD LIKE TO BEND THE PLANK IN ITS WIDER DIRECTION, BUT ARE THEN FACED WITH THE PROBLEM OF BUCKLING. THIS FIXTURE WILL BEND THE PLANK WITHOUTBUCKLING AND HOLD EVERYTHING IN PLACE UNTIL YOUR FAVORITE WOOD SOFTENER HAS HAD TIME TO DRY.

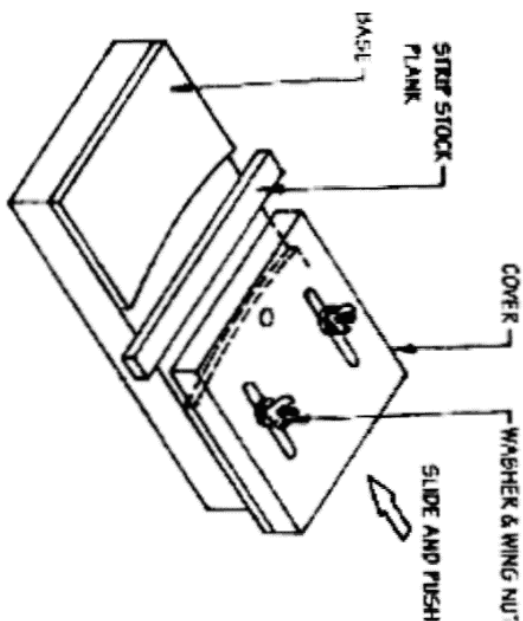

1. CONDITION PLANK WITH YOUR FAVORITE SOFTENER
2. LAY PLANK IN FIXTURE
3. SLIDE COVER OVER PLANK. THEN PUSH TO FORM.
4. TIGHTEN WING NUTS
5. LET DRY
6. REMOVE PLANK

Mark Your Calendar

July 26 & 27 The SubCommittee Annual Regatta Johnston, RI

<http://www.subcommitte.com>

August 8-10 Wisconsin Maritime Museum Model Boat and Ship Show and Contest

maritime@lakefield.net

October 9-12, 2003 30th Annual Nautical Research Guild Conference Chicago, Illinois.

<http://www.naut-res-guild.org/services/confer.html>

The '**BROADAXE**' is published monthly by The Ship Model Society of Northern New Jersey, a nonprofit organization dedicated to teaching and promoting ship modeling and maritime history. Membership dues are \$20.00 for the first year and \$15.00 per year thereafter.

Visit our Web Site at:

<http://www.njshipmodelsociety.org>

where an Web version of the **BROADAXE** can be found. The **BROADAXE** is distributed by both US mail and e-mail in PDF format.

Regular meetings are held on the fourth Tuesday of every month at 7:30 P.M., at the Millburn Free Public Library, 200 Glen Avenue, Millburn, New Jersey. Guests are always welcome.

Contributions to the **BROADAXE** are always welcome, and SMSNNJ members are encouraged to participate. Articles, shop hints and news items may be submitted directly to The Editor as typed manuscript or electronic files, either on discs or by e-mail. Handwritten notes or other materials will be considered depending on the amount of editing and preparation involved.

Direct All Correspondence To:

BROADAXE EDITOR

David C. Watkins, 4 Knollwood Ave, Madison, NJ 07940
E-mail: david.watkins19@verizon.net

OFFICERS

PRESIDENT:

Ed Hegstetter, 79 Cypress Point Lane, Jackson, NJ 08527
(732) 928-1140 E-mail: jeheg@optonline.net

VICE PRESIDENT:

Barry Rudd, 1600 Well Drive, Fair Lawn, NJ 07410
(201) 791-1431 E-mail: metrolimo@aol.com

TREASURER:

Jeffrey Fugelstad, 73 Rensselaer Road, Essex Fells, NJ 07021
(973) 228-3230 E-mail: boatworks1@worldnet.att.net

SECRETARY:

Thomas McGowan, 36 Clover Hill Lane, Colts Neck, NJ 07722
(732) 946-8322 E-mail: jmcgcla@aol.com

WEBMASTER:

Dave Watkins, E-mail: david.watkins19@verizon.net

THE BROADAXE

NEWSLETTER

of

THE SHIP MODEL SOCIETY OF NORTHERN NEW JERSEY

Founded in 1981

Volume 21, Number 27

July 2003

Newsletter Editor:

David Watkins

4 Knollwood Ave.

Madison, NJ 07940

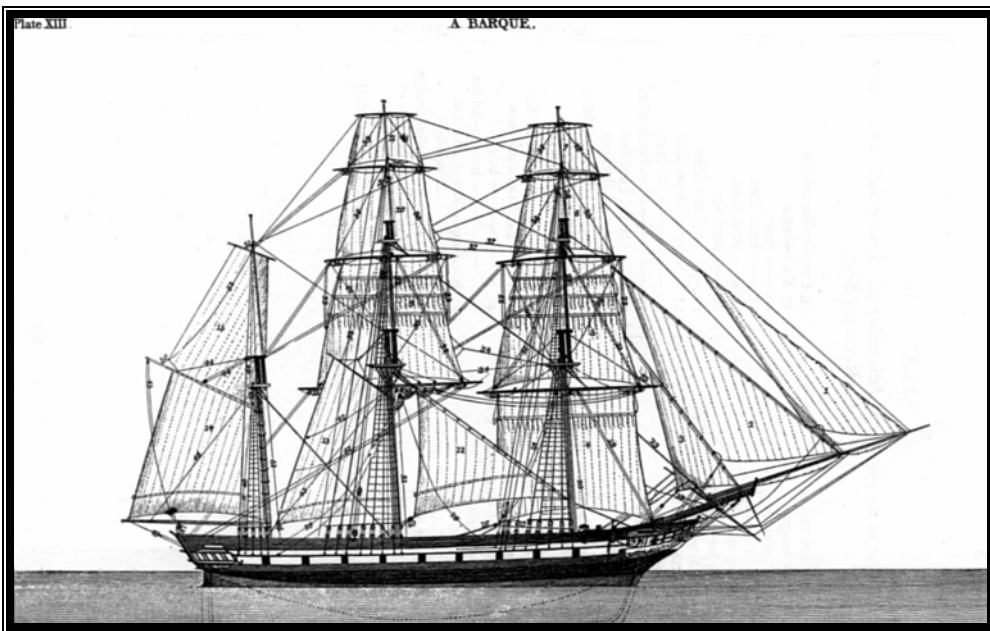

NEXT MEETING:

**July 22, 2003
7:30 PM**

**MILLBURN
PUBLIC
LIBRARY**

Technical Session

**To Be
Announced**